

Fences can be placed at the top of a Keystone® wall with fence posts placed either into the Keystone® units or behind the Keystone® units. Follow these procedures for proper installation of fence posts.

1. Install the Keystone® wall per general installation instructions.
2. Select the fence post position. If fence posts will be placed into the Keystone® units, the Standard Keystone® Unit must be used for the retaining wall construction. The fence post may be placed in one of two positions: (1) the front unit void or (2) the tail section unit void. Posts placed in the Keystone® unit void may be spaced in unit multiples of 1.5' (45.7cm) (i.e., 6', 7.5', 9', 10.5', 12' O.C.)(1.8m, 2.3m, 2.7m, 3.2m, 3.7) Do not allow unit core fill material (i.e., gravel) or backfill material to collect in the voids of the units into which the post will be placed. A separation membrane such as building paper may be used for this. Posts may be anchored with concrete fill. A steel sleeve may be used as an option. Cap units installed on a wall with fence posts in the front unit void may need to be cut for a proper fit.
3. Fence posts positioned behind the Keystone® units may be installed and anchored using standard installation methods. This position is recommended for retaining walls constructed using the Compac Keystone® Unit. Posts would be placed by normal construction methods for anchoring. If the wall is reinforced with geogrid, the guard rail post may be placed by cutting holes in the geogrid layers as needed per the recommendations of the geogrid manufacturer.

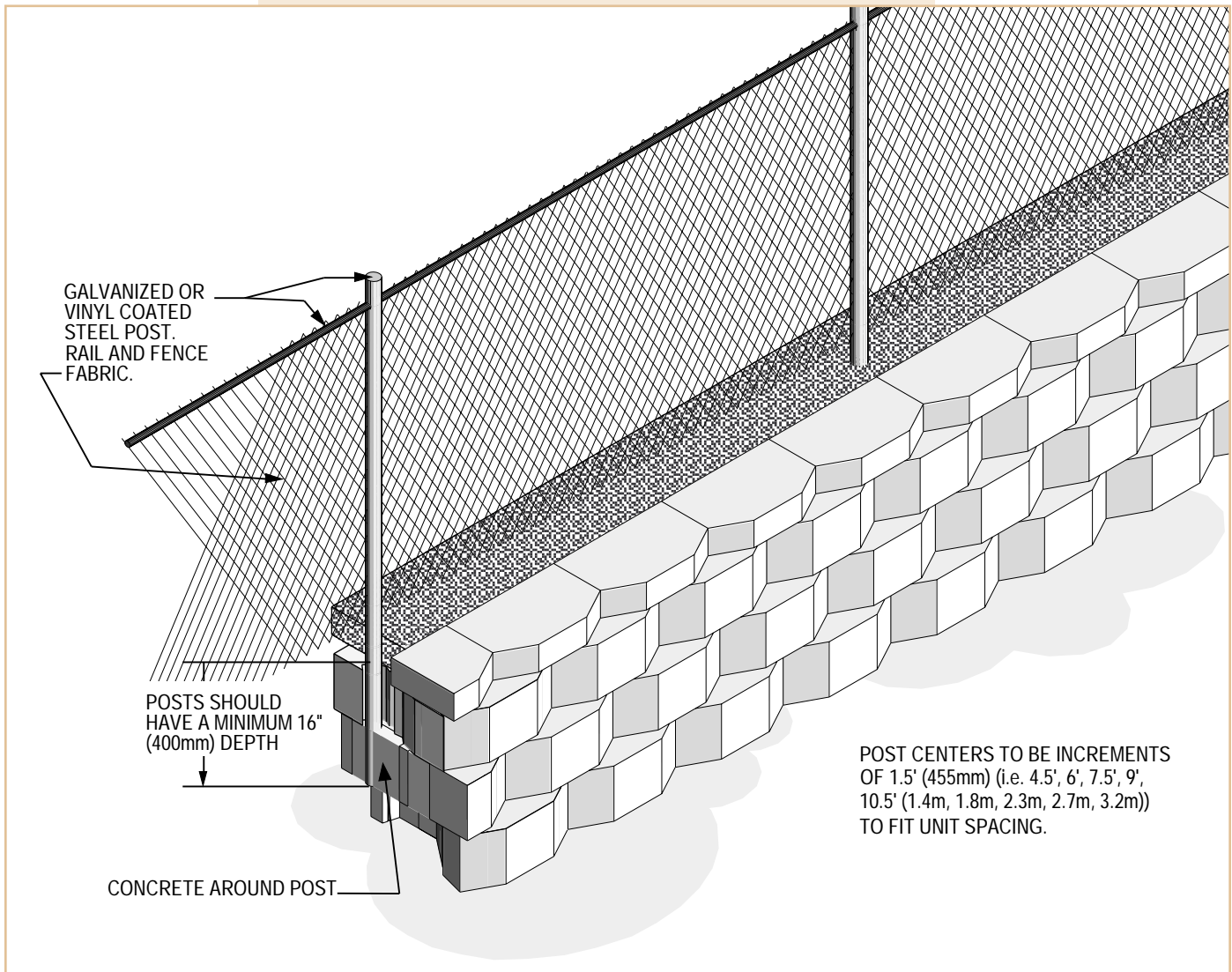

▷ REAR CORE POSITIONING

▷ FIRST COURSE

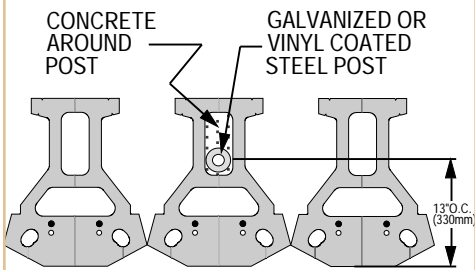

▷ SECOND COURSE

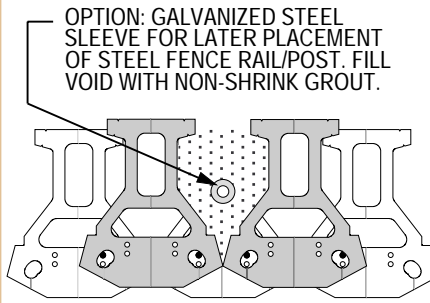

▷ CAP COURSE

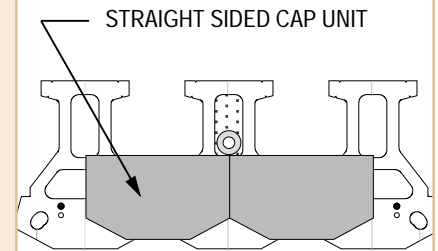

▷ FRONT CORE POSITIONING

▷ FIRST COURSE

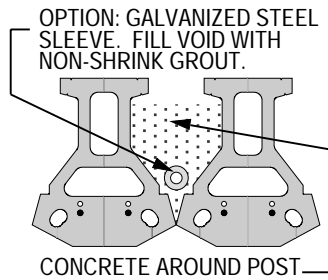

▷ SECOND COURSE

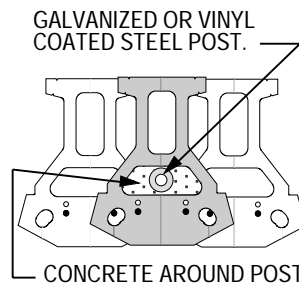

▷ CAP COURSE

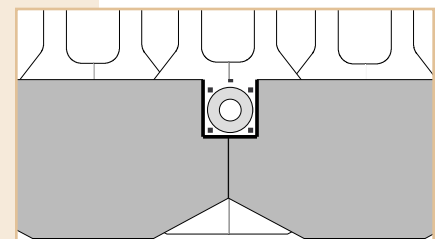
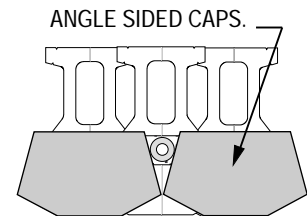

IF USING STRAIGHT SIDED CAPS, CUT UNITS AS REQUIRED FOR PIPE.

